

View Tile

Features

- View Tiles within the floor and are walkable, making valuable floor space available for maintenance clearance and egress requirements
- Constructed with high quality materials
- Available in half or full view tile
- Pre-engineered to be compatible with all raised floor systems
- Features optional Medeco lock that limits access to facility components
- Features latch that enables user easier access to maintain facility components
- Optional safety frame maintains walkability even while lid is open
- Custom color matching to align with your existing facility
- Carbon steel and powder coated frame
- Customized module configuration facility enclosure for facility components such as ducts, piping and electricity

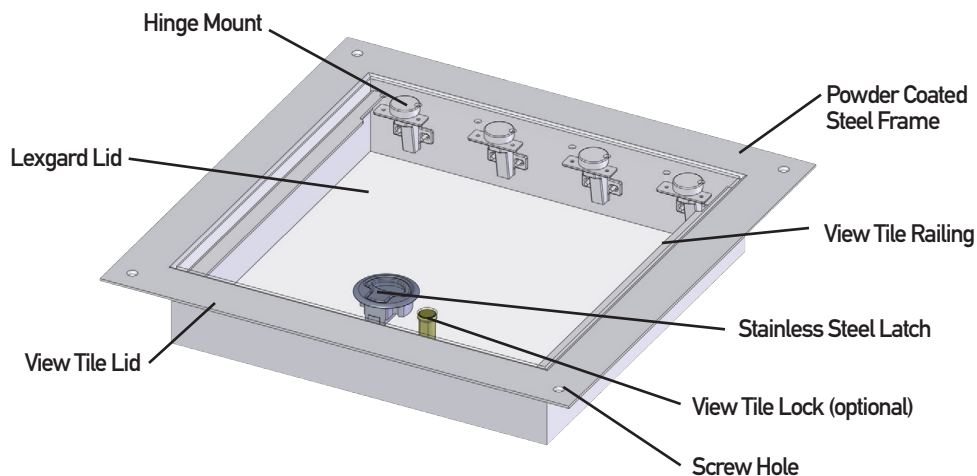

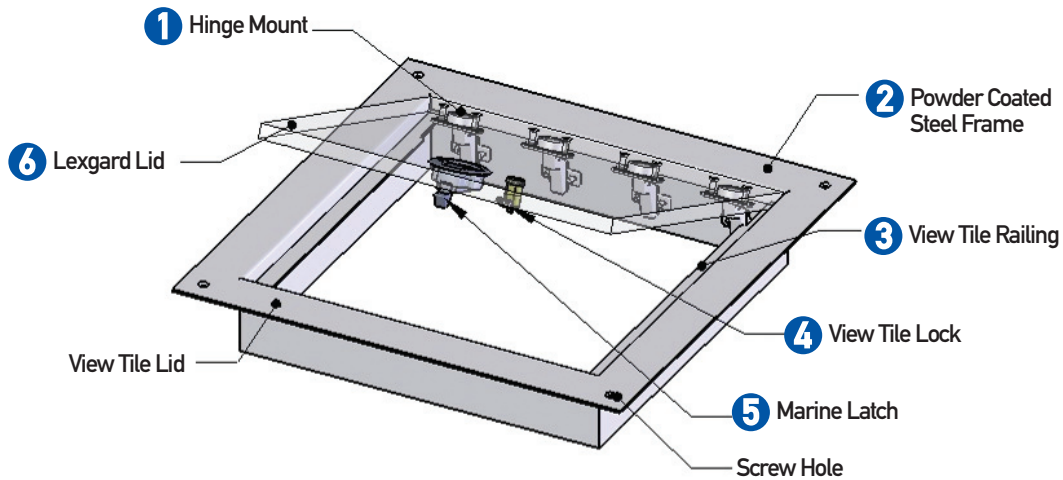

Part Number	Description	Quantity
1	22-Hinge Liberty Hinge	4
2	22-Frame Powder Coated Steel Frame	1
3	22-Railing Railing and Accessory	1
4	22-Lock or equivalent (optional) Medeco Lock or equivalent	1
5	22-Latch Stainless Steel Latch	1
6	22-Lexgard or equivalent 3/4" Lexgard Lid or equivalent	1
7	22-Vented (optional) Lexgard Lid Vented	1

Available Options

- Model Size: 2' x 2' or 2' x 4'
- Raised Floor Type: Dawtech, Tate, etc.
- Color: Custom Color Matching
- Lock: Optional
- Lid Vent Perforations: Optional
- Safety Frame: Optional



340 Avenue D, Suite #40
Williston, VT 05495 USA